



***INTERNATIONAL INDIVIDUAL FACETING
CHAMPIONSHIP***

and

INTERNATIONAL FACETING TEAMS COMPETITION

SCHEDULE and DESIGNS 2016

**INTERNATIONAL INDIVIDUAL
FACETING CHAMPIONSHIP**

AND

INTERNATIONAL FACETING TEAMS CHALLENGE

2016

Introduction

The International Faceting Challenge, sponsored by the Australian Facetors' Guild Limited, is a two-part competition open to all experienced Facetors from around the world.

The primary competition is the Individual Faceting Championship where each entrant shall cut the three stones specified in this schedule.

The International Faceting Teams Challenge consists of 5 entries from countries or regions that have sufficient entrants to make up a team from the Individual Faceting Championship.

IFC 2016 CO-ORDINATOR

The only contact for all matters pertaining to the Championship & Challenge is:

**Rod Turville
PO Box 4334
Ashmore
QLD 4214
AUSTRALIA**

Telephone number: (from within Australia) 0407750635

(from outside Australia) +61407750635

E-mail address: **rod.turville@bigpond.com**

A. BOTH COMPETITIONS: ORGANISATIONAL ASPECTS

- A1. Every effort is made to ensure that this Competition Schedule is available to potential entrants at least 12 months prior to the competition and will be available for viewing and download from the Australian Facetor's Guild Website:

www.facetorsguild.com.au

- A2. **Entry & return postage fees can be by direct debit or by PayPal.**

If you are a member of the Australian Facetors' Guild ensure to insert your membership number in the reference field, or if not a member, place your surname in the reference field. The transfer of funds is to be sent to the bank of the Australian Facetors' Guild Limited. details below.

Direct Debit: ANZ Bank. BSB: 014 271. Account No. 3140 32304.

Swift Code: ANZ BAU 3M (this code is only for overseas entry.)

OR

PayPal : **accounts@facetorsguild.com.au**
(add \$2.00 for PayPal account processing)

- A3. Entrants shall mail their stones by airmail to the address given on the entry form. It is strongly suggested that overseas entrants label their packages "Lapidary Competition Entries To Be Returned", **with no reference to gemstones.** To minimise possible difficulties with Australian Customs, it is recommended that entrants include a copy of their entry form with their stones, and put a **nominal** value on the customs declaration forms which must be affixed to the package.
- A4. Entry fees, insurance, packaging, full postage (to & from) is the responsibility of each competitor. Each stone is to be labelled with the section number, material name, size of stone, colour, cut and, if possible, accurate carat weight, each placed in a separate container within the whole package.
- A5. **The closing date for entries is:**

1st August 2015

- A6. Results of these competitions will be announced, and all entries will be displayed at the Australian National Gem and Mineral Show, **March 25th to March 28th, 2016 in Ulverstone, Tasmania, during the 2016 GEMBOREE®.**
- A7. Entries together with judging sheets will be carefully repacked and returned as indicated on the entry form as soon as possible after the conclusion of the 2016 GEMBOREE®.
- A8. The Committee will exercise every possible care of the stone entries, but it cannot be held responsible for any loss or damage during transportation, judging, displaying or storage.

Schedule and Conditions

B. INTERNATIONAL INDIVIDUAL FACETING CHAMPIONSHIP

- B1. This is a level 3 competition, i.e. one for which entries are actively solicited from two or more Australian States and/or overseas countries.
- B2. The Individual Faceting Championship shall be contested every two years.
- B3. All entrants are eligible for this competition, irrespective of whether or not they are members of a faceting guild or club. Membership of the Australian Facetors' Guild Limited is not a prerequisite for entry.
- B4. An entry will comprise the three stones cut by an entrant.
- B5. The individual winner will be the entrant with the highest aggregate points for his/her three stones.

C. INTERNATIONAL FACETING CHALLENGE: TEAM COMPETITION

- C1. All entrants in the Individual Faceting Championship are eligible for the Team Competition.
- C2. The five entrants from each country/region who obtain the highest points for their three stones will constitute the team for their country/region and their points will be totalled. The highest total of these combined points will determine the winning country/region. To enable entrants from countries without teams to be involved in the team competition the top five entrants from these countries will be called 'the rest of the world team'.
- C3. The Challenge Cup, which is a perpetual trophy, will remain the property of the Australian Facetors' Guild Limited. The cup will be contested simultaneously with the Individual Faceting Championship.
- C4. The Challenge Cup will remain with the Australian Facetors' Guild regardless of the winner of the cup. The responsibility for security of the Challenge Cup will therefore be the duty of the Australian Facetors' Guild.
- C5. The Australian Facetors' Guild will make the Challenge Cup available bi-ennially, for display at the Australian Federation of Lapidary and Allied Crafts Associations' National Gem and Mineral Show held at Easter, for formal presentation to a representative of the winning country/region. (This Australian Gem and Mineral Show is held annually and is known as the GEMBOREE®).
- C6. The Challenge will be conducted by a committee from the Australian Facetors' Guild Limited, and will be financed by the Guild, by entry fees contributed by competitors, by donations from interested overseas guilds, and donations from any interested individuals.

D. AWARDS

- D1. Gold and Silver medallions shall be awarded for first and second place in the Individual competition as well as for members of the first and second place in the Teams competition. The winning team members will also be recognised by their names being added to the perpetual trophy for that year of the Challenge.

E. BOTH COMPETITIONS. TECHNICAL ASPECTS

- E1. Unless otherwise stated in Conditions of this Schedule, this Competition is staged and will be judged according to the Faceting Competition Rules in the Competitor and Judging Manual for Lapidary and Allied Competitions Issue No.7 dated April 2006, issued by the Australian Federation of Lapidary and Allied Crafts Association (AFLACA) An extract from these rules has been incorporated into this schedule.
- E2. The three cuts chosen for this Competition are considered to be of a technical nature to test the abilities of entrants. Faceters around the world are invited to submit designs for future selection, provided those designs are computer-generated with instructions.
- E3. The angles provided with the designs in this schedule are for the guidance only to entrants. Entrants may vary the angles to achieve meet points if desired, provided the original **plan view** of the shapes and arrangements of facets, meet points, and the table area of the design **is not changed** in any detectable manner. If the shape or arrangements of facets has in any way been altered, the entry will be disqualified, resulting in disqualification of the entrant; i.e. **the stone must be identical to the design in the schedule**. Caution is urged in changing angles. As can be seen from the Points Allocation, angles are not measured during judging.
- E4. Magnification for judging will be with a 10X Triplet Loupe.
- E5. All stones will be judged under lighting having a maximum equivalent to a single 25 - 40w clear incandescent lamp.
- E6. Entries are limited to only one set of three stones per entrant. Each entry is deemed to cover three stones - one in each Section named in this Schedule.
- E7. A completed entry form constitutes acceptance of this Schedule and Conditions, and is an agreement to comply with them.
- E8. No person is permitted to act as Judge, Judge's Assistant, Steward, Observer, or in any way to assist with the judging of any Section of which he/she or members of his/her immediate family are entrants. Members of the organising committee may compete in the competition but are subject to the restrictions stated in this clause.
- E9. (Protests). If an entrant believes that one or more of his/her stones has not been scored correctly, he/she may lodge an appeal to the IFC Committee setting out the precise details of his/her complaint. The appeal, which must be in writing, should be lodged as soon as possible but **must be submitted by 31/4/2016**.
- E10. (Protests). The stone/stones in question along with a copy of the original judging sheet must be returned to the IFC Committee in Australia and must be accompanied by the written appeal to the IFC Committee. In accordance with the conditions in the original schedule, the entrant must pay any freight and insurance.
- E11. (Protests). The IFC Committee will refer the appeal (and hand over the stone/stones) to the Judging and Rules (J&R) Committee of the Australian Faceters' Guild Limited for adjudication. The adjudication will be made as near as possible under the same conditions that applied in the original judging. (e.g. magnification, lighting).
- E12. (Protests). The J&R Committee shall adjudicate on the appeal as soon as possible. None of these J&R Committee members shall be members of the IFC Committee. They shall not have been involved in the original judging and shall not be related to the appellant.
- E13. (Protests). The decision of the Judging and Rules (J&R) Committee shall be **FINAL** and no further correspondence shall be entered into.

COMMENTS FROM THE COMPETITION COMMITTEE

Angles.

The designs included in this Schedule are the latest computer - generated diagrams. The angles given are for materials selected by the designer. Competitors are expected, where necessary, to convert the design angles given to angles suitable for the nominated material. The Committee does not guarantee either the precision of the angles given or the listed sequences for cutting.

Size.

Entrants should be careful to ensure that the size of their stones conforms to the Schedule. Please read the Schedule carefully.

It is strongly recommended that the material chosen be of a light colour. See next note.

Visual Effect

The following feature now applies:-

As of 2014 the Optical Penalty has been removed from the points allocation and Visual Effect included to take its place. This is to allow our judges to use the judging criteria that they use in all Australian competitions so as not to cause confusion.

The cutting of a stone with inferior optical properties - "windows", or "fish eyes", and overall dullness - cannot be ignored, and such cutting will be penalised.

This will be done by subtracting points from the Visual Effect allocation depending on the degree of effect on the stone as observed by the Judge.

Dull stones, resulting from incorrect angles or poor selection of dark rough material, will be similarly treated. Ray trace patterns are not used in the judging process, but may be used to assist the Committee in selecting designs which, if cut correctly, will produce bright, attractive stones.

2016 INTERNATIONAL FACETING CHALLENGE SECTIONS

Entry is COMPULSORY in each of the three sections detailed below.

SECTION A

FLAME PENDANT 4

To be cut in Colourless Cubic Zirconia
Minimum size 20mm \pm .1mm across longest axis.

SECTION B

CC DIAMOND BARION

To be cut in Man Made Corundum
Minimum size 8mm \pm .1mm across shortest axis.

SECTION C

PINEBERRY

To be cut in Coloured Quartz
Minimum Size 15mm \pm .1mm across longest axis.

JUDGING POINTS ALLOCATION

SECTION A

This is a Fancy Cut and will be judged under the following set of points using the AFLACA standard judging sheet as shown below.

Section 11 - FANCY CUTS

JUDGE..... SECTION No.

ENTRY No.

DESCRIPTION SIZE

HEIGHT Max GIRDLE WIDTH DIAGONAL

No. of Facets No. of Meets

Visual Effect	6		
# Outline of Girdle	4		
# Table Parallel to Girdle Plane.....	3		
# Meets Pointing Up	16		
Facets Uniform	13		
Facet Edges Sharp	6		
Facet Surfaces True	6		
Scratches	10		
Polish	10		
Chips	7		
Flaws	4		
# Girdle Uniform	3		
# Girdle Too Wide	3		
# Orientation of Crown & Pavilion Facets .	8		
Foreign Surface Material	1		
# Modified Total	#		
TOTAL POSSIBLE	$\frac{\text{Points} \times 100}{\#}$	100	

In types of cuts where any of these features do not apply, the points shown for each inapplicable feature are to be subtracted from 100, and total points gained will be divided by the remainder, then multiplied by 100 to give a percentage result.

JUDGE COMMENTS

JUDGE SIGNATURE DATE

SECTION B

This is a Modified Standard Cut and will be judged under the following set of points using the AFLACA standard judging sheet as shown below

Section 10 - MODIFIED STANDARD CUTS

JUDGE SECTION No.

ENTRY No.

DESCRIPTION SIZE

HEIGHT Max GIRDLE WIDTH DIAGONAL

No. of Facets No. of Meets

***Competition Committee to indicate whichever is applicable**

***Continuous Girdle**

***Faceted Girdle**

	6	Visual Effect	6		
	4	Outline of Girdle	5		
	3	Table Parallel to Girdle Plane	3		
	16	Meets Pointing Up	19		
	13	Facets Uniform	15		
	6	Facet Edges Sharp	6		
	6	Facet Surfaces True	6		
	10	Scratches	10		
	10	Polish	10		
	7	Chips	7		
	4	Flaws	4		
	3	Girdle Uniform	5		
	3	Girdle Too Wide	3		
	8	Orientation of Crown & Pavilion Facets ...	0	xxxxx	xxxxx
	1	Foreign Surface Material	1		
	100	TOTAL POSSIBLE	100		

JUDGE COMMENTS

JUDGE SIGNATURE DATE

SECTION C

This is a Modified Standard Cut and will be judged under the following set of points using the AFLACA standard judging sheet as shown below.

Section 10 - MODIFIED STANDARD CUTS

JUDGE SECTION No.

ENTRY No.

DESCRIPTION SIZE

HEIGHT Max GIRDLE WIDTH DIAGONAL

No. of Facets No. of Meets

***Competition Committee to indicate whichever is applicable**

***Continuous Girdle**

***Faceted Girdle**

	6	Visual Effect	6	
	4	Outline of Girdle	5	
	3	Table Parallel to Girdle Plane	3	
	16	Meets Pointing Up	19	
	13	Facets Uniform	15	
	6	Facet Edges Sharp	6	
	6	Facet Surfaces True	6	
	10	Scratches	10	
	10	Polish	10	
	7	Chips	7	
	4	Flaws	4	
	3	Girdle Uniform	5	
	3	Girdle Too Wide	3	
	8	Orientation of Crown & Pavilion Facets ...	0	XXXXX XXXXX
	1	Foreign Surface Material	1	
	100	TOTAL POSSIBLE	100	

JUDGE COMMENTS

JUDGE SIGNATURE DATE

B5. METHOD OF JUDGING:

- B5.1 Competitions held in accordance with this Manual are to be judged by AFLACA Accredited Judges.
- B5.2 Each entry is not judged against its competitors, but is assessed against an established standard and the resulting score is the measurement of excellence achieved, or how nearly it reaches the standard.
- B5.3 The conditions and definitions of this Manual should be interpreted sensibly and in all cases where there is doubt, the Competitor shall be given the benefit.
- B5.4 All entries in an individual Section must be judged by the one Judge.
- B5.5 Entries in Showcase, Fossil and Mineral Groups are judged in place in the position placed by the Entrant or their nominated Carrier. They are not handled for judging purposes.
(NOTE: This clause does not apply in this or other faceting competitions).
- B5.6 No person is permitted to act as Judge, Judge's Assistant, Steward, or in any way assist with the judging of any Section of which he/she or members of his/her immediate family are entrants.
- B5.7 No person, other than Judges, Assistants or Stewards, is permitted in the vicinity of exhibits whilst judging is in progress.
- B5.8 No one, including Assistants and Stewards, is permitted to influence Judges in the execution of their duty.
- B5.9 Only the Competition Committee can rule ineligible an entry or an item which is part of an entry. The reason for ruling an item ineligible must be written on the judging sheet and signed by the Competition Committee.

However, JUDGES MUST CONSULT WITH COMPETITION COMMITTEE if they consider an entry or part of an entry is ineligible.
- B5.10 For penalties refer to individual Section definitions and conditions.
- B5.11 Entries will be judged by eye or at the specified magnification as given for each Competition Section.
- B5.12 Entries will be judged under the lighting conditions given with Section Definitions and Conditions.
- B5.13 Entries will be judged on the judging features set out on the sample Points Allocation Sheets given for each Section in the Competition Schedule.
- B10. JUDGE RESPONSIBILITIES:**
- B10.1 Judges shall assess each judging feature applicable to the Section being judged and award points according to how near to the standard it reaches.
- B10.2 Judges shall assess all entries in a Section at the magnification specified in the Manual OR in the Schedule. Some Sections in the Manual allow Competition Committees to nominate the magnification.
- B10.3 Judges are not required to total up points on judging sheets. This is the responsibility of the Competition Committee.
- B10.4 Judges do not rule on eligibility - this is the Competition Committee's responsibility. However, should a Judge suspect an entry is not eligible, or they are uncertain on any interpretation of the rules and conditions, they MUST refer the matter to the Competition Committee for a ruling.
- B10.5 Judges should, whenever possible, give constructive comments on the work judged and be prepared to discuss rulings and interpretations with Competitors.
- B10.6 When an entry has been ruled ineligible, the Judge shall judge the entry if so requested by the Competition Committee, in the interests of helping the competitor. However, the points will not be displayed or recorded and the entry will not be eligible for any awards. The Competition Committee MUST write on the judging sheet INELIGIBLE and give reasons for the ruling.
- B10.7 Where practical, Judges are expected to provide their own equipment required for Judging assignments, e.g. hand-held or head magnifying loupes, desk lamps etc.

A.F.G. INTERNATIONAL FACETING CHALLENGE 2016

OFFICIAL ENTRY FORM

This Form **AND** Entries must reach the Competition Committee by **1 August, 2015** at the following address:

**A.F.G. International Faceting Challenge 2016
PO Box 4334
Ashmore
Queensland 4214
AUSTRALIA**

Name

Address

CitySTATE.....

COUNTRYPost (Zip) Code

Telephone Number

E-mail Address (important)

ALL SECTIONS ARE COMPULSORY:

Entry Fee

AUD\$40.00

My entries will be collected at the GEMBOREE® :

OR

Return postage by REGISTERED POST :

Return Postage

AUD\$

Total

AUD\$

VERY IMPORTANT NOTE

Entry & return postage fees can be by direct debit or by PayPal.

Direct Debit: ANZ Bank. BSB: 014 271. Account No. 3140 32304.

Swift Code: ANZ BAU 3M (this code is only for overseas entry.)

PayPal : accounts@facetorguild.com.au

(add \$2.00 for PayPal account processing)

No refund of fees will be considered under any circumstances.

I have read and agree to follow and abide by the rules of this competition and hereby state that the stones entered by me are my own work.

I understand that failure to abide by these rules may lead to disqualification of my entries.

Signed: Date:/...../.....

A.F.G. INTERNATIONAL FACETING CHALLENGE 2016

SECTION A

FLAME PENDANT 4 COLOURLESS CZ

MINIMUM SIZE 20mm ± .1mm Across Longest Axis

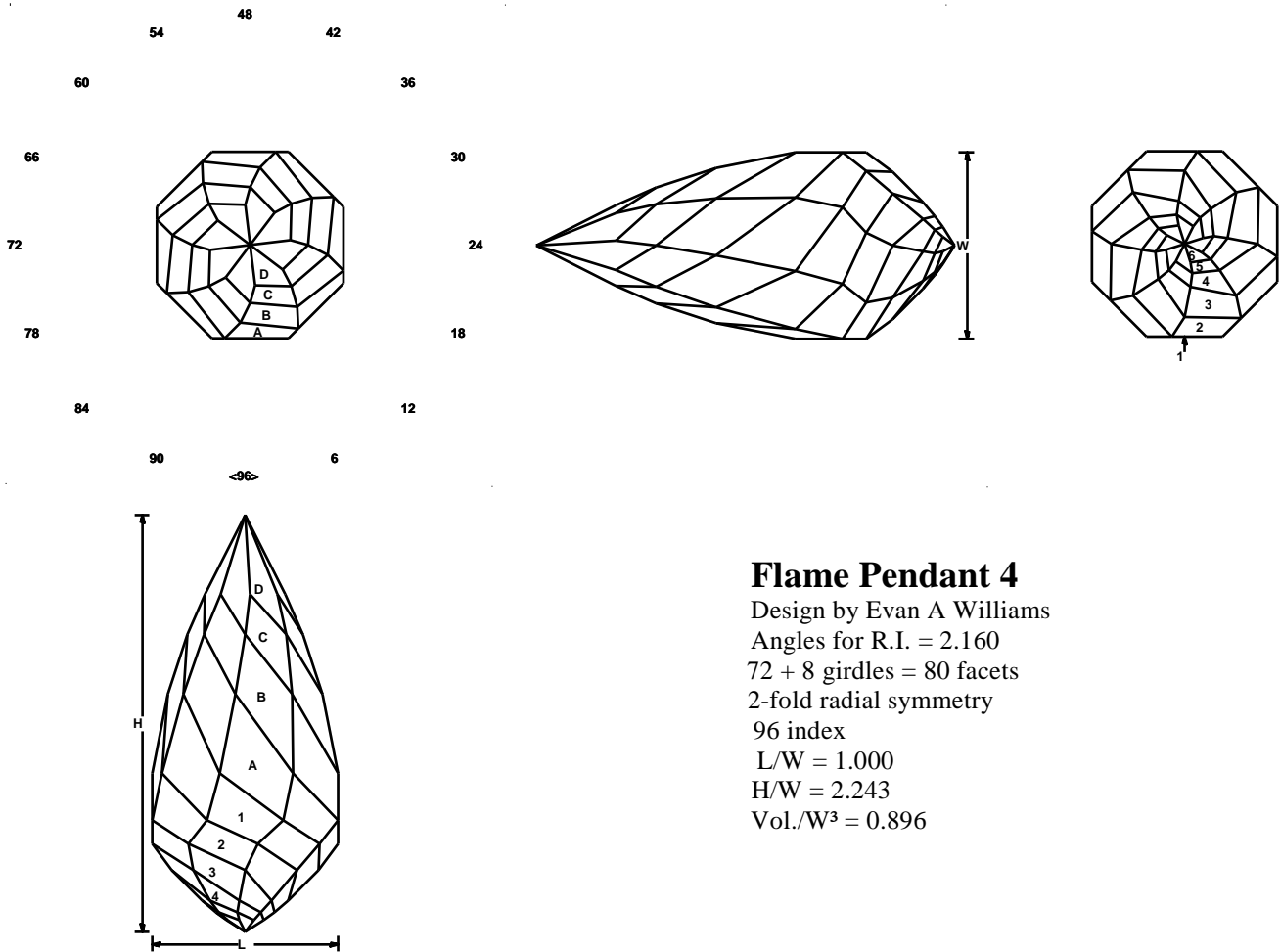

Flame Pendant 4

Design by Evan A Williams

Angles for R.I. = 2.160

72 + 8 girdles = 80 facets

2-fold radial symmetry

96 index

L/W = 1.000

H/W = 2.243

Vol./W³ = 0.896

PAVILION

Facet	Angle	Facet Numbers	Description
1	90.00°	96-12-24-36-48-60-72-84	Establish shape
2	60.00°	04-16-28-40-52-64-76-88	Locate tier – Use same mast height setting
3	50.00°	06-18-30-42-54-66-78-90	MP at 1-2-2
4	45.00°	08-20-32-44-56-68-80-92	MP at 2-3-3
5	38.00°	10-22-34-46-58-70-82-94	MP at 3-4-4
6	35.00°	11-23-35-47-59-71-83-95	MP at 4-5-5 - Form PCP

CROWN

Facet	Angle	Facet Numbers	Description
A	80.00°	02-14-26-38-50-62-74-86	MP at 1-1-2
B	75.00°	04-16-28-40-52-64-76-88	MP at 1-A-A
C	70.00°	06-18-30-42-54-66-78-90	MP at A-B-B
D	65.00°	08-20-32-44-56-68-80-92	MP at B-C-C – Form PCP

A.F.G. INTERNATIONAL FACETING CHALLENGE 2016

SECTION B

CC DIAMOND BARION MM CORUNDUM

MINIMUM SIZE 8mm ± .1mm Across Shortest Axis

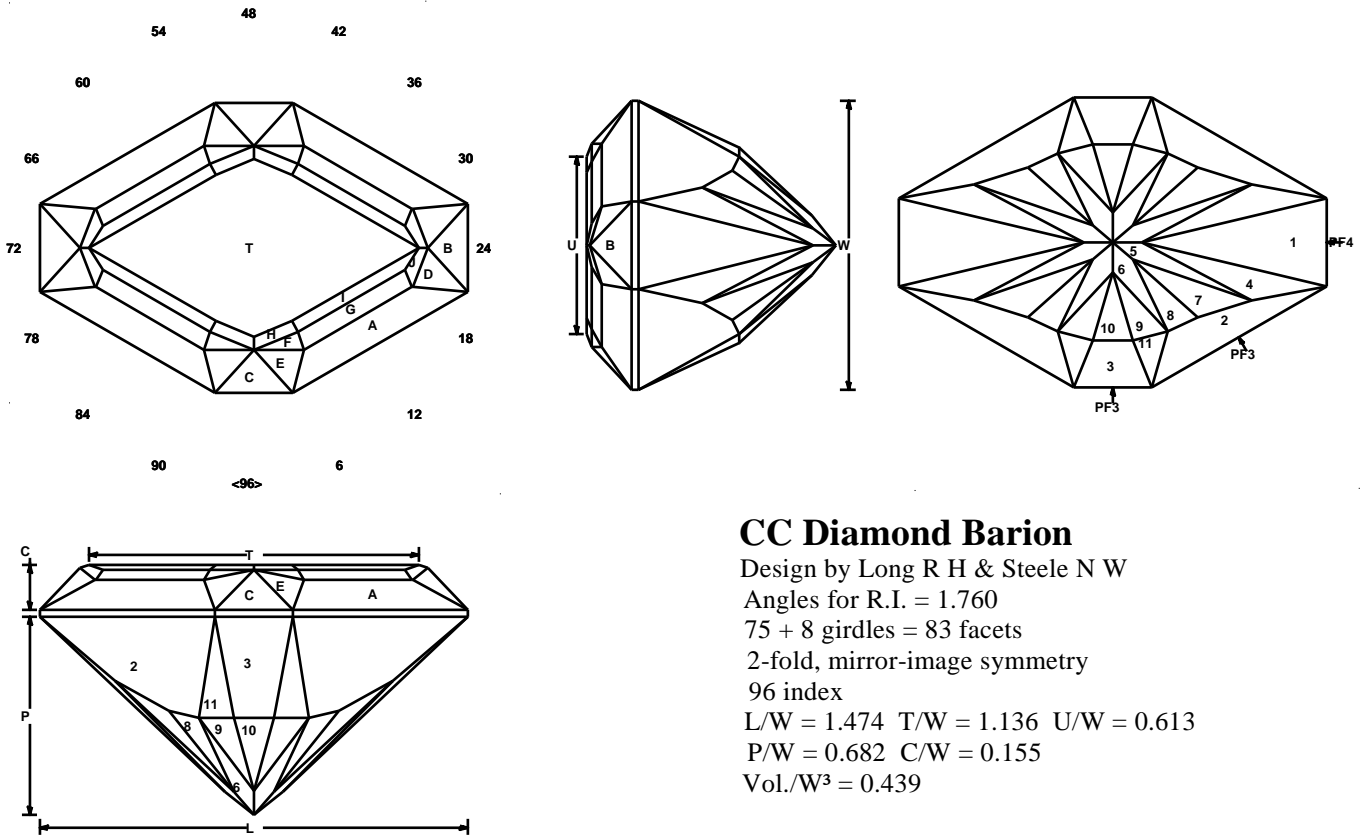

CC Diamond Barion

Design by Long R H & Steele N W

Angles for R.I. = 1.760

75 + 8 girdles = 83 facets

2-fold, mirror-image symmetry

96 index

L/W = 1.474 T/W = 1.136 U/W = 0.613

P/W = 0.682 C/W = 0.155

Vol./W³ = 0.439

PREFORM

PF1 35.00° 96-08-40-48-56-88 Cut to TCP

PF2 25.41° 24-72 Meet at TCP

PF3 90.00° 96-08-40-48-56-88 Establish size

PF4 90.00° 24-72 Level temp girdle

PAVILION

1 43.48° 24-72 Locate final girdle

2 68.00° 08-40-56-88 Level girdle

3 65.00° 96-48 "

4 42.70° 20-28-68-76 GMP at 1-2

5 42.00° 16-32-64-80 MP at 1-4-4 - Form PCP

6 43.00° 08-40-56-88 Cut to PCP

7 43.00° 14-34-62-82 MP at 2-4-5

8 43.50° 10-38-58-86 MP at 5-6-7

9 45.80° 04-44-52-92 MP at 2-6-8

10 47.00° 96-48 MP at 6-6-9-9

11 63.51° 04-44-52-92 GMP at 2-3 - MP at others

CROWN

A 43.27° 08-40-56-88 Set girdle width

B 46.55° 24-72 Level girdle

C 42.88° 96-48 "

D 35.27° 12-36-60-84 GMP at A-B

E 37.77° 04-44-52-92 GMP at A-C

F 27.69° 06-42-54-90 MP at C-E-E

G 28.12° 08-40-56-88 MP at A-E-F

H 22.00° 06-42-54-90 MP at C-E-E-F-F

I 22.00° 08-40-56-88 MP at F-G-H

J 28.67° 10-38-58-86 MP at B-D-D

T 0.00° Table MP at I-I-J-J

A.F.G. INTERNATIONAL FACETING CHALLENGE 2016

SECTION C

PINEBERRY COLOURED QUARTZ

MINIMUM SIZE 15mm ± .1mm Across Longest Axis

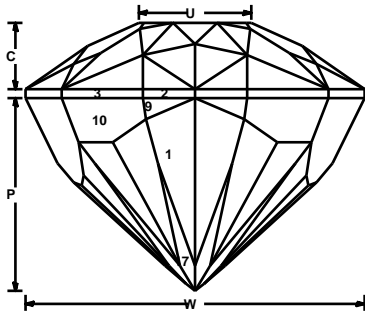
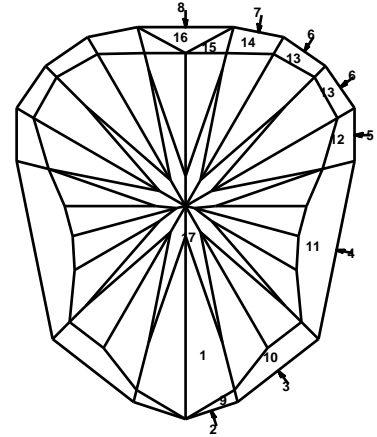
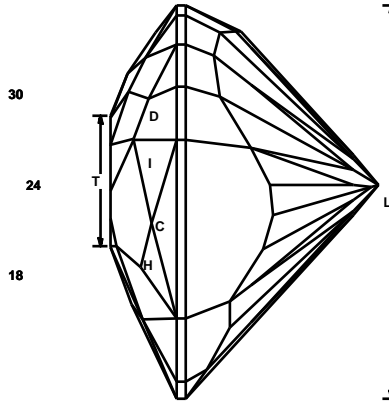
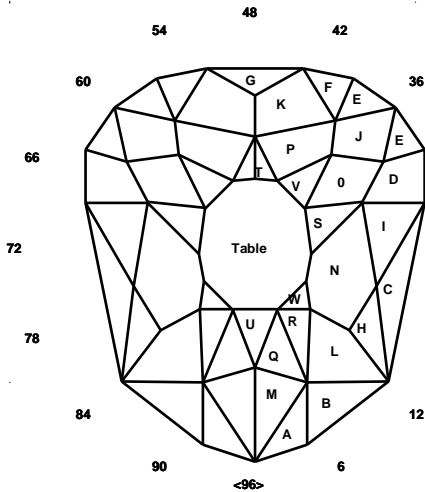

Pineberry

Design by Arya Akhavan and courtesy of The Gemology Project

Angles for R.I. = 1.540

98 + 15 girdles = 113 facets

1-fold, mirror-image symmetry

96 index

L/W = 1.161 T/W = 0.385 U/W = 0.332

P/W = 0.570 C/W = 0.196

Vol./W³ = 0.330

PAVILION

Facet	Angle	Facets	Notes
1	42.50°	02-06-10-14-18-22-26-30-34-38-42-46-50-54-58-62-66-70-74-78-82-86-90-94	Cut to TCP
2	90.00°	05-91	Set length - Start OMNI
3	90.00°	10-86	MP at 1-1-2
4	90.00°	21-75	MP at 1-1-3
5	90.00°	24-72	MP at 1-1-4
6	90.00°	33-39-57-63	MP at 1-1-5
7	90.00°	45-51	MP at 1-1-6
8	90.00°	48	MP at 1-1-7
9	59.56°	05-91	MP at 1-2 - Establish girdle
10	61.45°	10-86	Level girdle
11	65.48°	21-75	"
12	63.83°	24-72	"
13	60.48°	33-39-57-63	"
14	61.75°	45-51	"
15	62.16°	47-49	"
16	64.73°	48	"
17	42.00°	04-12-28-36-44-52-60-68-84-92	MP at 1-11-12 (only 2 facets meet)

CROWN

Facet	Angle	Facets	Notes
A	30.36°	05-91	Set girdle width
B	34.96°	10-86	Level girdle
C	39.80°	21-75	"
D	34.72°	24-72	"
E	34.96°	33-39-57-63	"
F	34.96°	45-51	"
G	38.99°	48	"
H	34.96°	20-76	GMP at B-C
I	34.96°	22-74	GMP at C-D
J	30.94°	36-60	GMP at E-E
K	33.43°	46-50	GMP at F-G
L	29.51°	13-83	GMP at B-C-H
M	25.45°	02-94	GMP at A-A
N	30.07°	21-75	MP at C-H-I
O	22.84°	30-66	MP at D-E-J & D-I-N
P	25.69°	44-52	MP at E-F-J-K
Q	22.47°	03-93	MP at A-B-L-M
R	22.11°	07-89	MP at A-B-L-M-Q
S	22.00°	26-70	MP at D-I-N-O
T	22.58°	47-49	MP at K-K-P-P
U	20.51°	96	MP at M-M-Q-Q
V	18.34°	36-60	MP at J-O-P
W	13.95°	12-84	MP at L-N-R & Q-R-U
Table	0.00°	Table	Table